

SPAREPART LIST PRO

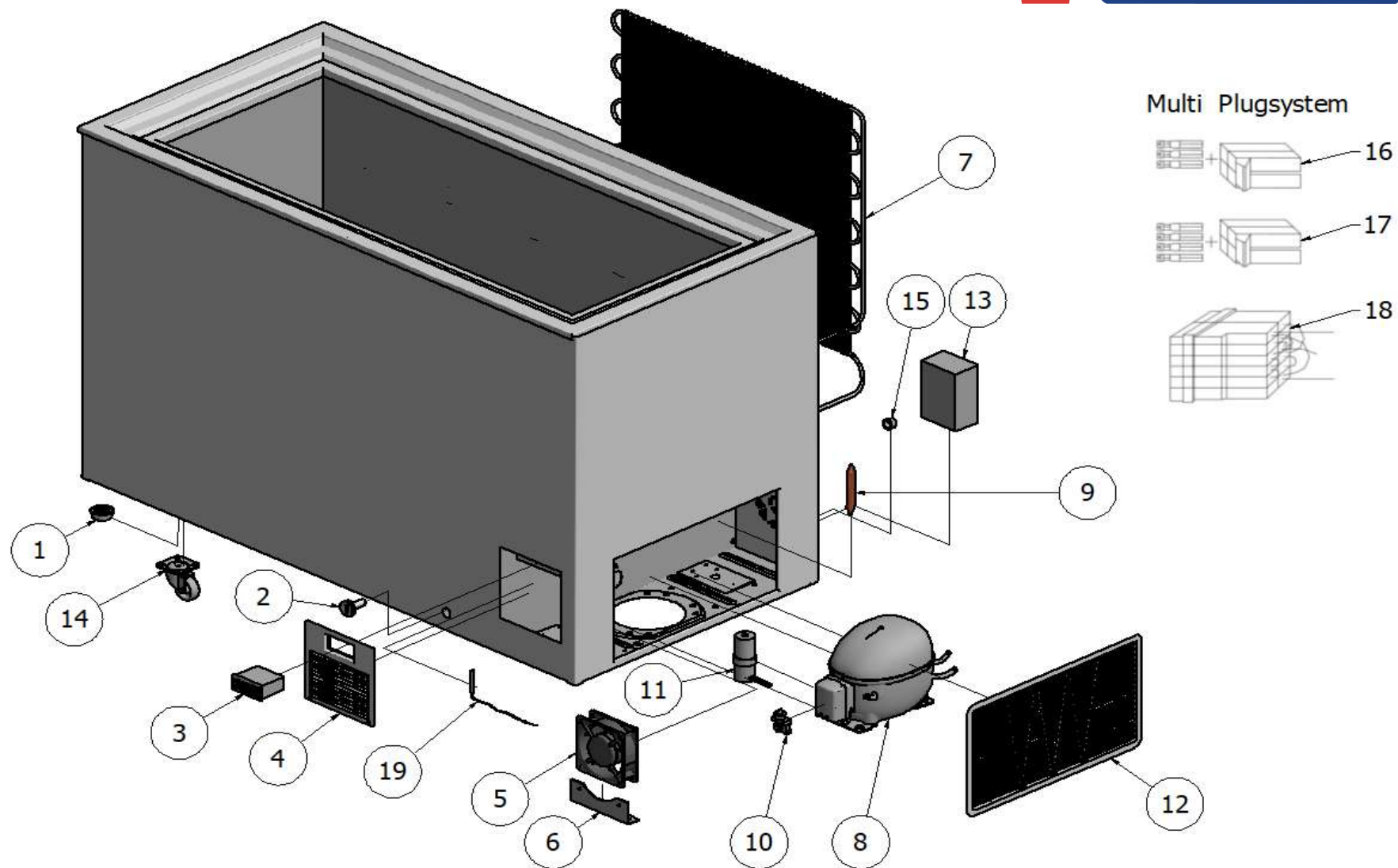



ITEM NO.	PCS	DESCRIPTION	MODEL 11		MODEL 21		MODEL 31		MODEL 41		MODEL 51/60	
			CODE		CODE		CODE		CODE		CODE	
1	4	Plastic foot	SP1412 SP1413		SP1412 SP1413		SP1412 SP1413		SP1412 SP1413		SP1412 SP1413	
2	1	Stopper for drain	E1HU		E1HU		E1HU		E1HU		E1HU	
3	1	Electronic thermostat 220V excl. sensor	DIXELL30CH2		DIXELL30CH2		DIXELL30CH2		DIXELL30CH2		DIXELL30CH2	
4	1	Front ventilation grill	PLASTMFP13		PLASTMFP13		PLASTMFP13		PLASTMFP13		PLASTMFP13	
5	1	Fan 220V	BLÆS230HBT		BLÆS230HBT		BLÆS230HBT		BLÆS230HBT		BLÆS230HBT	
6	1	Bracket for fan	Beslag BL		Beslag BL		Beslag BL		Beslag BL		Beslag BL	
7	1	Back precondensor	Kondryg1		Kondryg3		Kondryg3		Kondryg4		Kondryg4	
8	1	Compressor 230V 50/60Hz R290	NEU2140U		NEU2140U		NEU2155U		NEU2168U		NEU2168U	
9	1	Filter Dryer	Filter6.1xh9		Filter6.1xh9		Filter6.1xh9		Filter6.1xh9		Filter6.1xh9	
10	1	Starting Relay	NEU2140URE		NEU2140URE		NEU2155URE		NEU2168URE		NEU2168URE	
11	1	Starting Capacitor	NEU2140USK		NEU2140USK		NEU2155USK		NEU2168USK		NEU2168USK	
12	1	Cover for motor room	SP1417		SP1417		SP1417		SP1417		SP1417	
13	1	Alarm box incl. Cables	8100.0500		8100.0500		8100.0500		8100.0500		8100.0500	
14	4	Wheel set w/brake	8100.0201		8100.0201		8100.0201		8100.0201		8100.0201	
15	1	Cable retainer	E59AFLAST1		E59AFLAST1		E59AFLAST1		E59AFLAST1		E59AFLAST1	
16	1	Power cable	82NETLED.8		82NETLED.8		82NETLED.8		82NETLED.8		82NETLED.8	
17	1	Cable from dixell to Multi plug	TSL0201		TSL0201		TSL0201		TSL0201		TSL0201	
18	1	Multi plug with cable	TSK0106		TSK0106		TSK0106		TSK0106		TSK0001	
19	1	PT1000sensor	PT1000sensor		PT1000sensor		PT1000sensor		PT1000sensor		PT1000sensor	

Lid and parts for XLT / PRO boxes

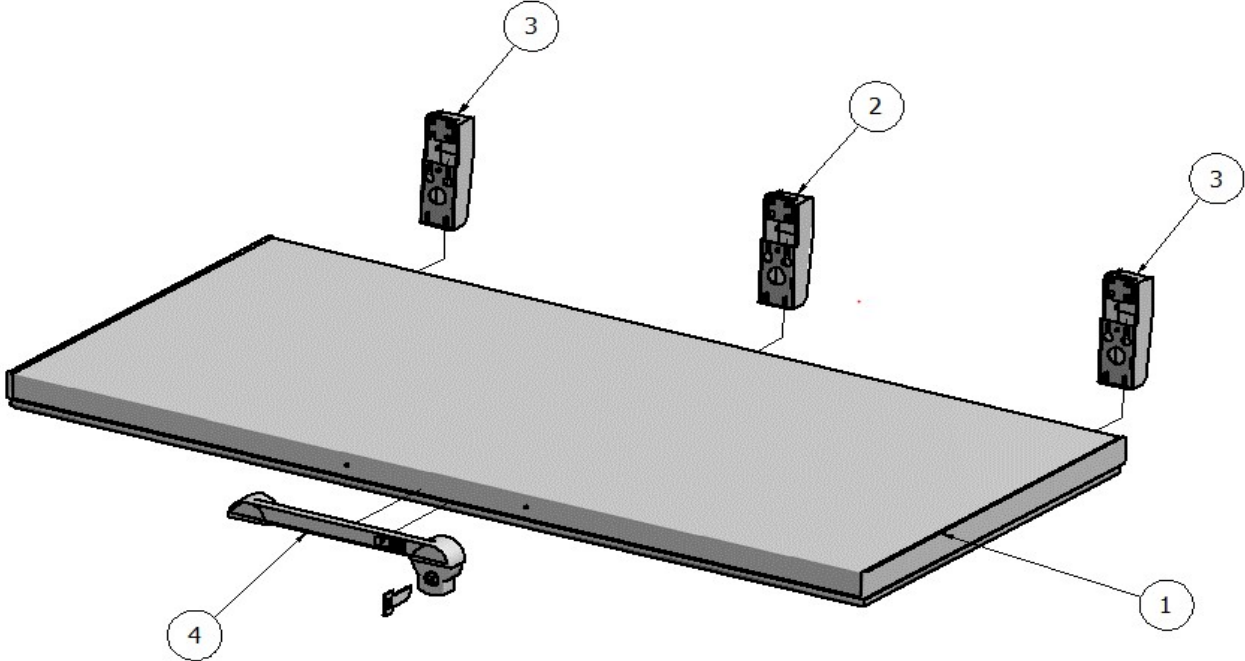

ITEM NO.	PCS	DESCRIPTION	MODEL 11		MODEL 21		MODEL 31		MODEL 41		MODEL 51/60	
			CODE		CODE		CODE		CODE		CODE	
1	1	Lid without hinges	8010.0100		8010.0200		8010.0302		8010.0402		8010.0502	
2	1	Hinge without spring	-		-		Haeng 00		Haeng 00		Haeng 00	
3	1	Hinges with spring	Haeng42 Haeng 42		Haeng 46 Haeng 46		Haeng 46 Haeng 46		Haeng 49 Haeng 49		Haeng 49 Haeng 49	
4	1	Plastic grip with lock	EPCH		EPCH		EPCH		EPCH		EPCH	

115 volt 60 Hz

UL SPEC.

ITEM NO.	PCS	DESCRIPTION	MODEL 11		MODEL 21		MODEL 31	
			CODE		CODE		CODE	
3	1	Electronic thermostat 115V Incl. sensor	DIXELL30CH1		DIXELL30CH1		DIXELL30CH1	
5	1	Fan115V	BLAES115HBT		BLAES115HBT		BLAES115HBT	
8	1	Compressor 120V 60HZ	NEU2155U1		NEU2155U1		NEU2155U1	
19	1	Multiplug with cable	TSKU0101		TSKU0101		TSKU0101	
12	1	Starting relay	NEU2155U1RE		NEU2155U1RE		NEU2155U1RE	
13	1	Starting capacitor	NEU2155U1SK		NEU2155U1SK		NEU2155U1SK	
	1	Motor protector/ KLIXON	NEU2155U1KL		NEU2155U1KL		NEU2155U1KL	